

# LESSON 27

## Warm-up

It's time to get your drawing talent introduced to the masses. Pick ten of your favorite drawings from your sketchbook. Send them to billboard companies in your area with a letter that reads:

Dear Billboard People,

I'm donating the enclosed drawings to our city's art cause. Please consider allotting some of your space to display these and other local masterpieces. You will not only help advance creative thinking, you will also be ahead of the nation when the President declares the first National Draw Squad Day.

Sincerely,

**DRAW SQUADER**  
(YOUR NAME)

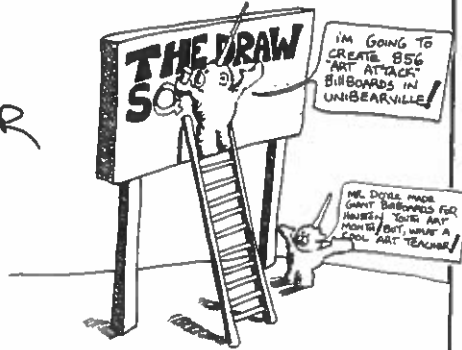

## The Key Drawing Word: **Advanced Overlapping**

**OVERLAPPING:** This occurs in drawing when an object in the composition appears to be in another object. **Overlapping** helps to create the appearance of depth in the drawing. When **overlapping** is combined with appropriate changes in size and detail (objects should be drawn smaller and less detailed if they are in the distance), a greater sense of depth is created.

Leslie Wingfield, Art Educator/Spring, TX

The key word symbol for **overlapping** is



Art Attack: Drawing #157

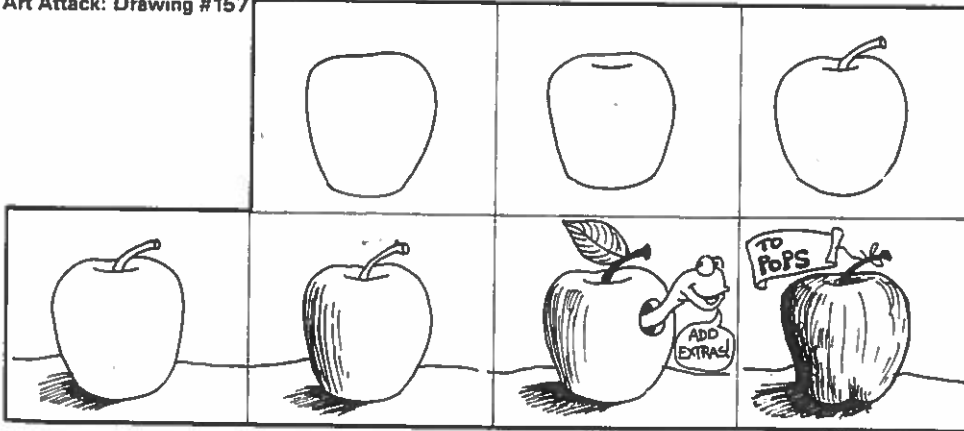

Art Attack: Drawing #158

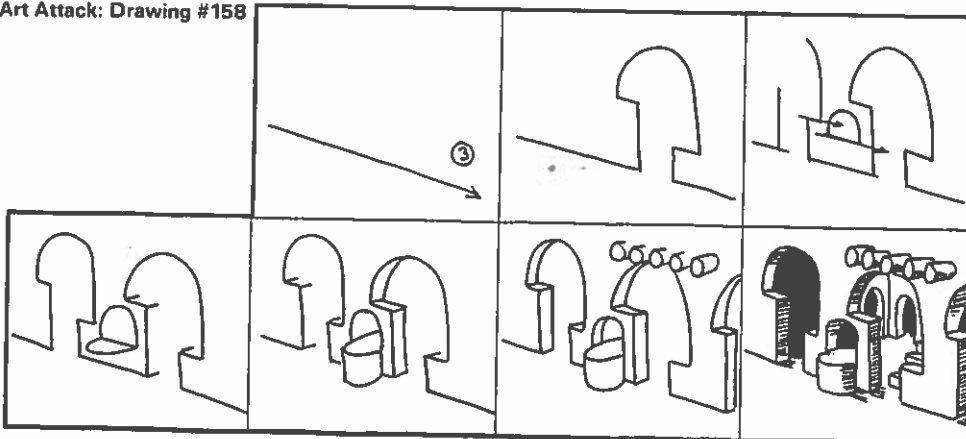

Art Attack: Drawing #159

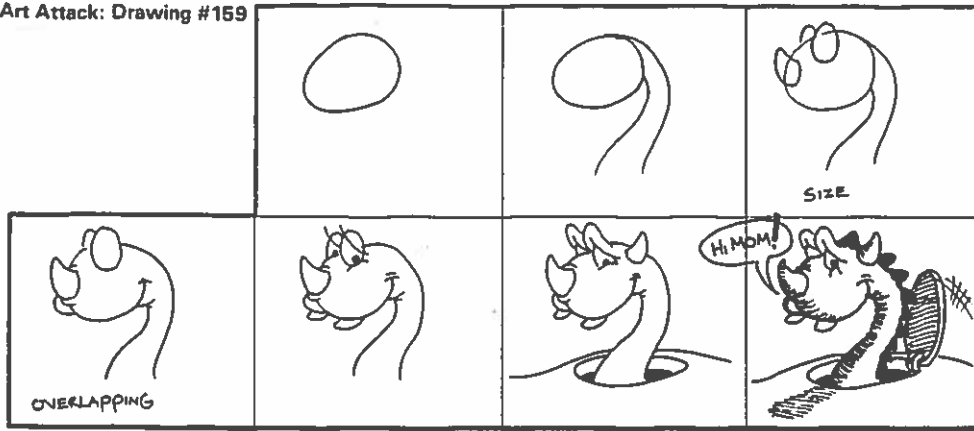

Art Attack: Drawing #160

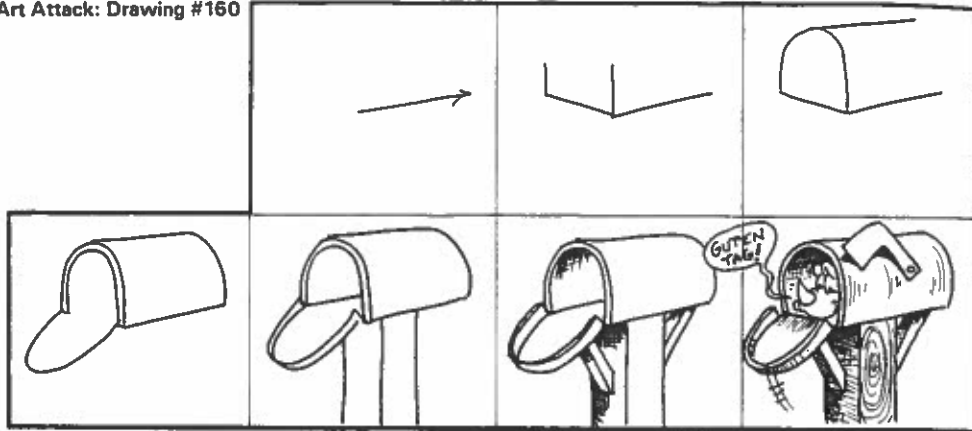

Art Attack: Drawing #161

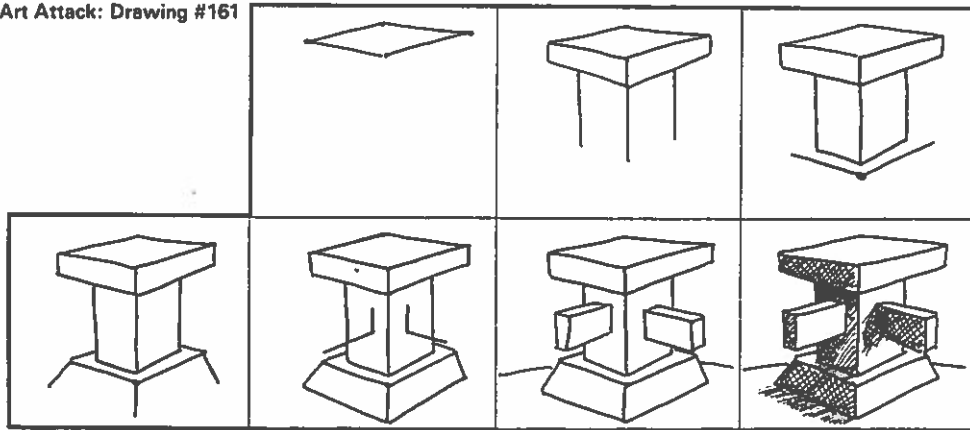

Art Attack: Drawing #162

