

LESSON 17

Warm-up

Here's a great warm-up from a good friend of mine, Amy "Art" Krichko, who teaches Art in Bitburg, West Germany:

"Relax...your arms and legs are melting into energy...feel that energy...everything around you is art...keep relaxing your arms...now your hands...fingers...fill your fingers with art energy."

NOW THAT YOU'RE ENERGIZED, put your hands in the air and wiggle them for 60 seconds with Drawercize. Ready to draw? Go, Go, Go!

Turn on your imagination! Fuel up your pencil with the Ten Key Words and launch across a blank piece of paper with pencil power... Explore the Land of Art. Imagine! Create! Experiment!

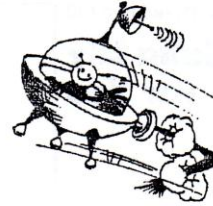

Key Drawing Word: **Intermediate Overlapping**

OVERLAPPING: Think of it as layering that helps to give your pictures depth. It is how you can make things look closer to you and other things look farther away. It is the means by which you can place, set, arrange and position one thing in front of another. **Overlapping**, along with the other elements of drawing, will turn ordinary flat drawings into spectacular three-dimensional drawings.

Margaret Hansen, 1st Grade Teacher, Montevideo School/San Ramon, C.



The key word symbol for **overlapping** is:

Art Attack: Drawing #97

**Uni-Ted
Goes For
a Morning
Spin**

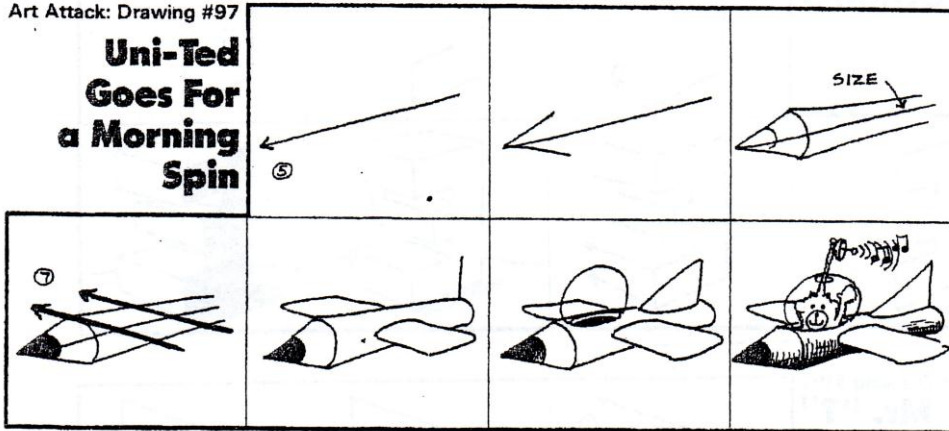

Art Attack: Drawing #98

**A Romance
Is Born**

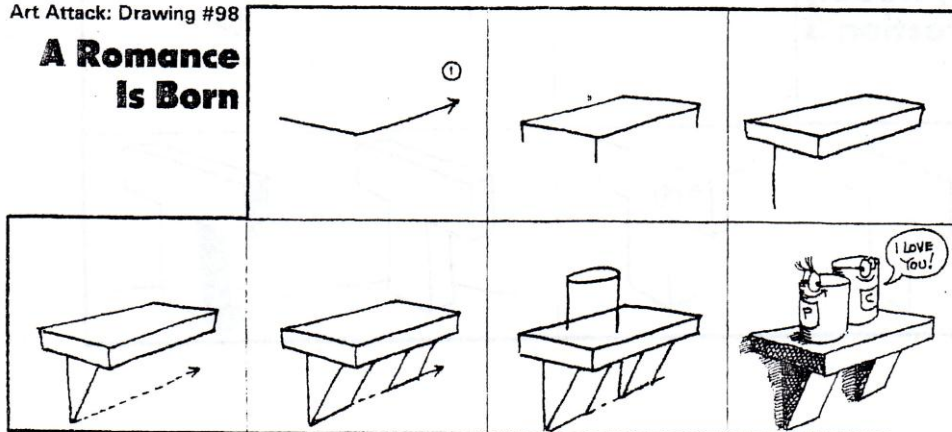

Art Attack: Drawing #99

The Official Draw Squad Chair

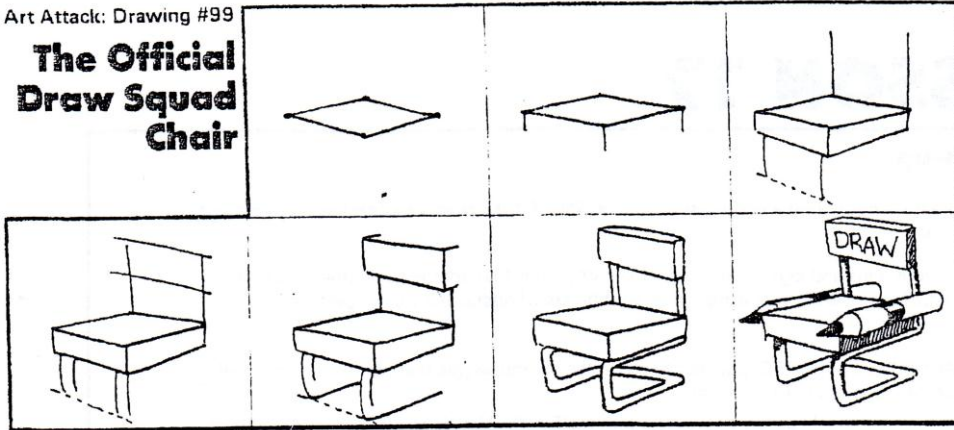

Art Attack: Drawing #100

A Calla Lily For You

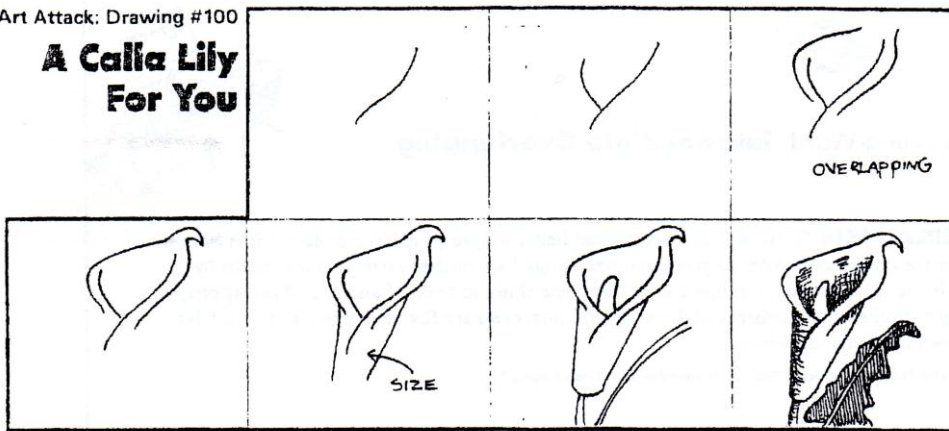

Art Attack: Drawing #101

Mr. "E" in Direction 3

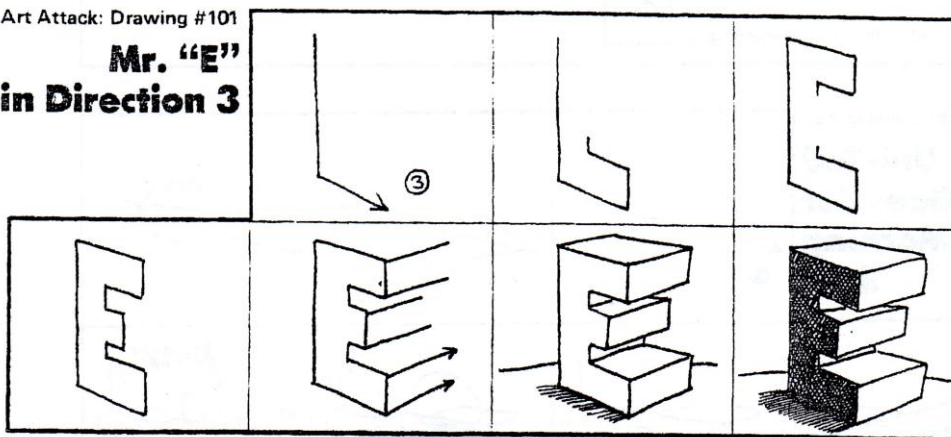

Art Attack: Drawing #102

Mr. "T" (Oh, Nooo!) in Direction 3

