

# LESSON 21

## Warm-up

I've got it! Let's start a Draw Squad Newsletter. Yeah! "Artsy" reading for millions of Draw Squaders. Everyone can send in drawings and ideas. I'll include a Key Word Review and a fun new lesson every issue. Wow, this is going to be fun! I can see it now. Draw Squad will become the *Time* magazine of the 90's. It'll be translated into 19,000 languages. I love it when these brilliant ideas strike. Your warm-up for today is to mail ten ideas to me for the Draw Squad Newsletter.



## Key Drawing Word: **Advanced Foreshortening**

**FORESHORTENING:** the closer a part of an image is to the viewer the larger it appears. **Foreshortening** establishes a view point for the observer and creates the illusion of depth. It allows the artist the opportunity of exaggeration and dramatic lighting effects. In television animation it is crucial in maintaining life-like movements and a sense of distance.

Tracy Stiffler, Professional Artist, WXXI T.V. 21/Rochester, NY

Create your own key word symbol for foreshortening



Art Attack: Drawing #121

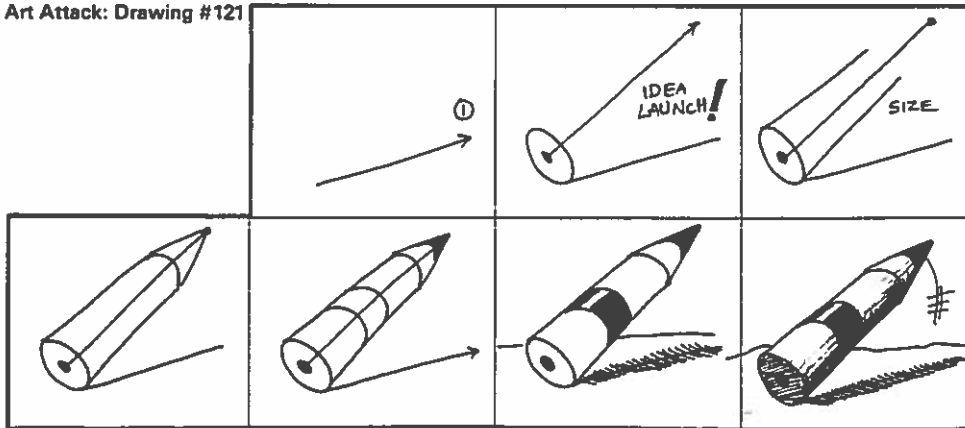

Art Attack: Drawing #122

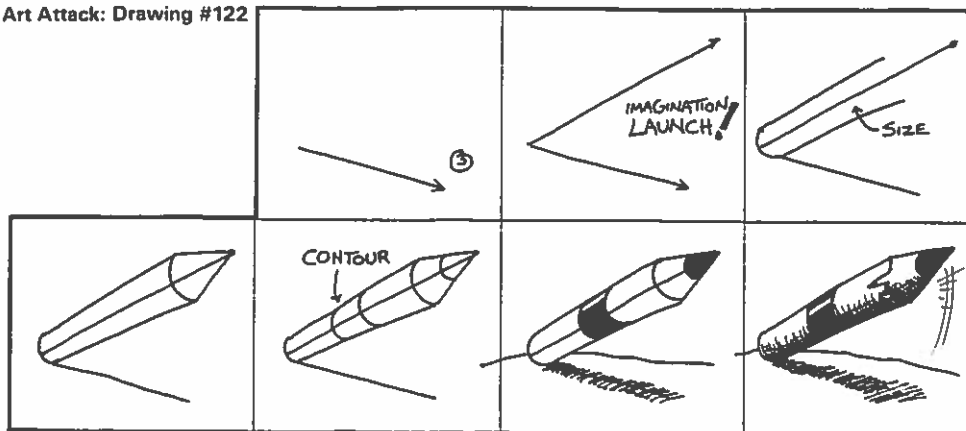

Art Attack: Drawing #123

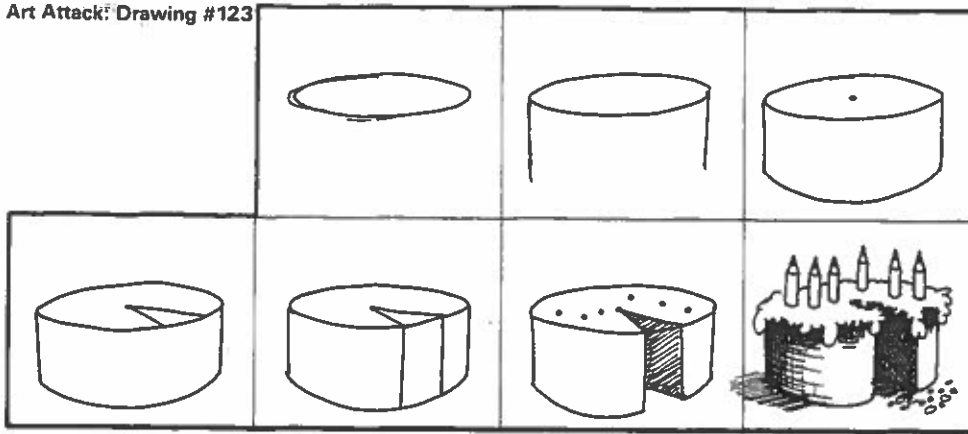

Art Attack: Drawing #124

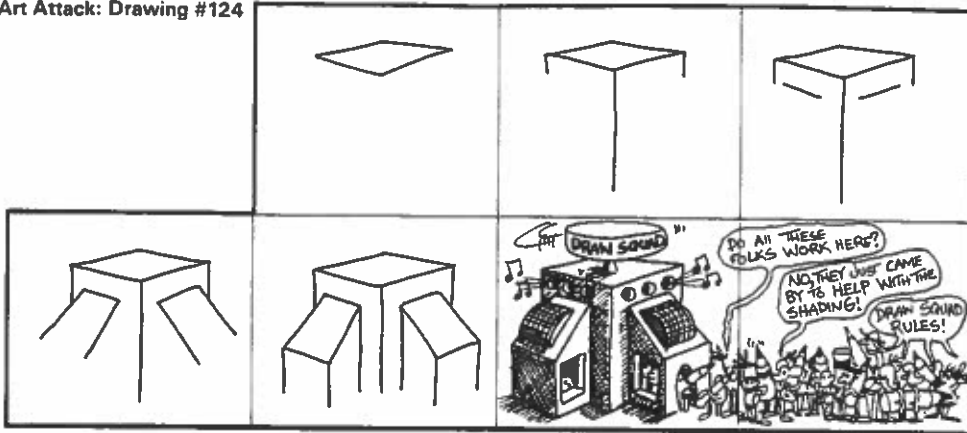

Art Attack: Drawing #125

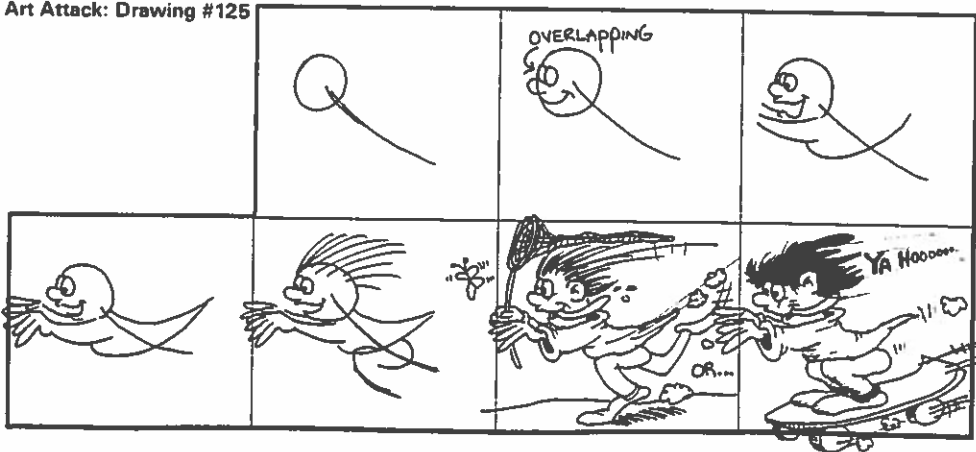

Art Attack: Drawing #126

