

LESSON 14

Warm-up

Warm-up by drawing the Draw Squad oath in 3-D 472 times! Here's the oath: "I, _____, being the shade artist that I am (Notice how we say *shade* instead of *cool*, it's a new trend that's sweeping the nation, a kind of Draw Squad Mania with you as the pacesetter!), promise to blast across the paper with pencil power everyday for a minimum of seven hours. I also promise to complete each 7-hour daily drawing lesson by teaching eight friends how to draw." In keeping with this oath, this planet will be Draw Squad saturated by 2010 A.D.



Key Drawing Word: Intermediate Shadow

SHADOW: In Holland we call this "plastycteyites," which translates to the drawn form of darkness opposite the light source, both on the object and the area near the object. Adding shadows next to and under the object will give your drawing the third dimension.

Hans van der Veen, Art Educator/Croningen, Netherlands



The key word symbol for shadow is

Art Attack: Drawing #79

A Mishap in Uni-Ted's Laboratory

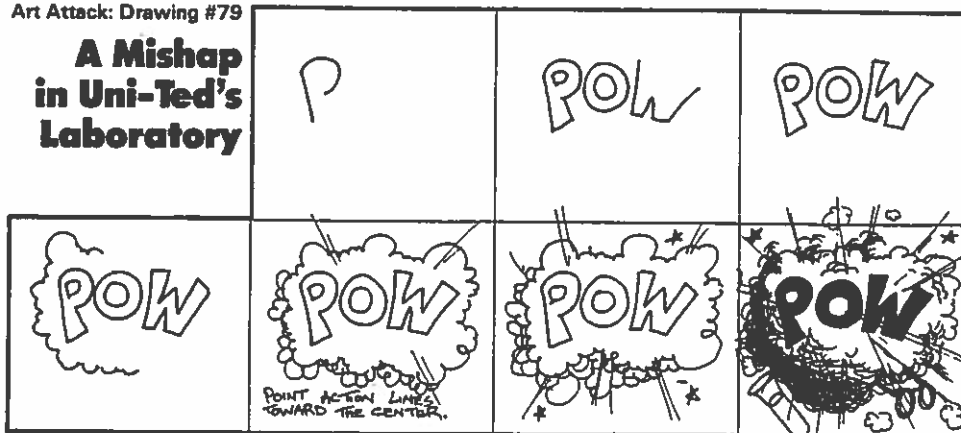

Art Attack: Drawing #80

Grandma's Gift

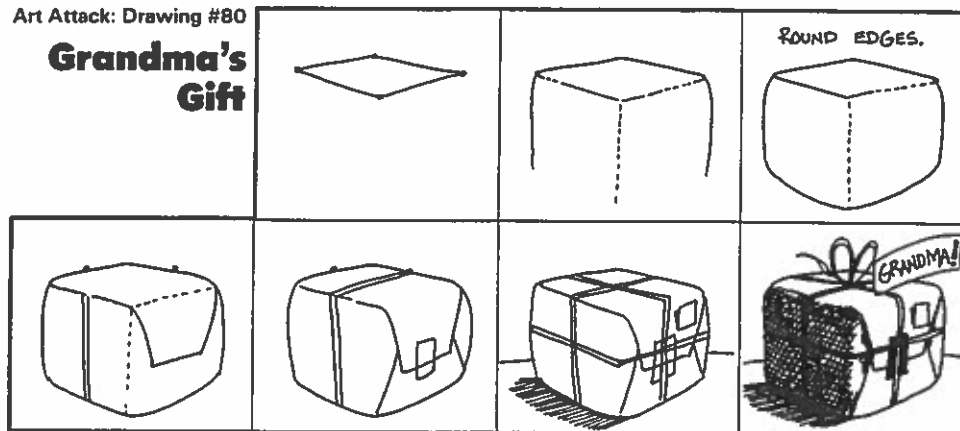

Art Attack: Drawing #81

Career Ladder

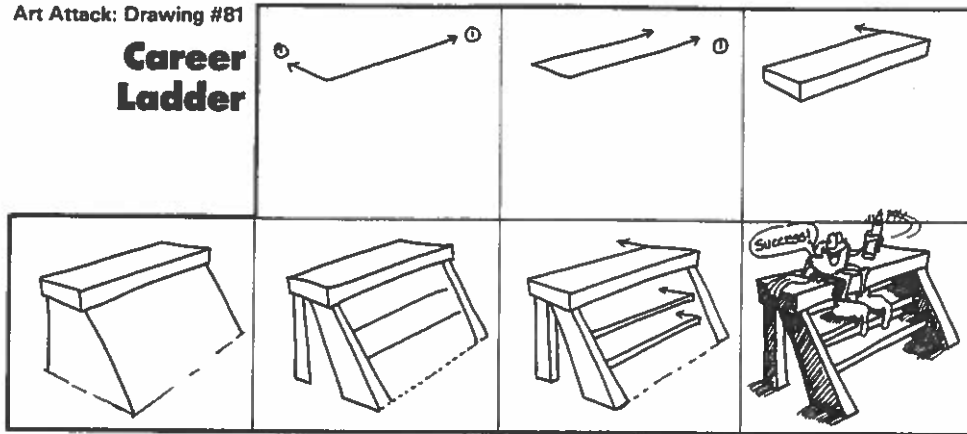

Art Attack: Drawing #82

The 3-D "E" xtra Button

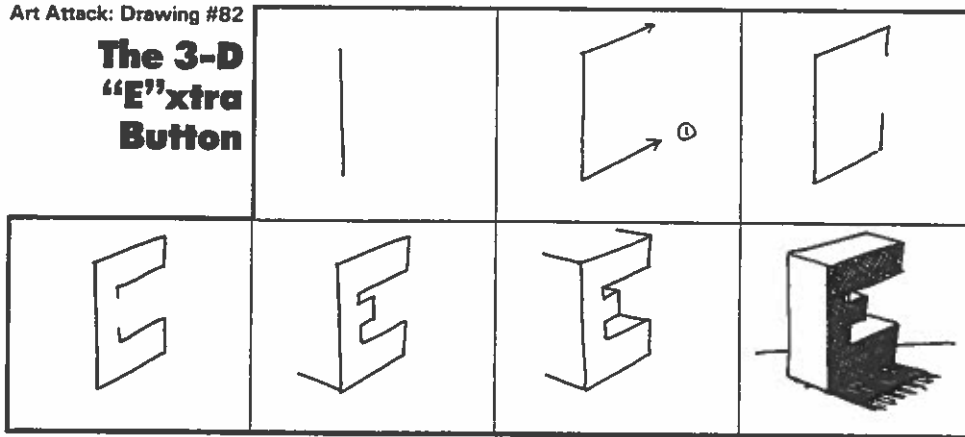

Art Attack: Drawing #83

"Oooh, It Has a Designer Label"

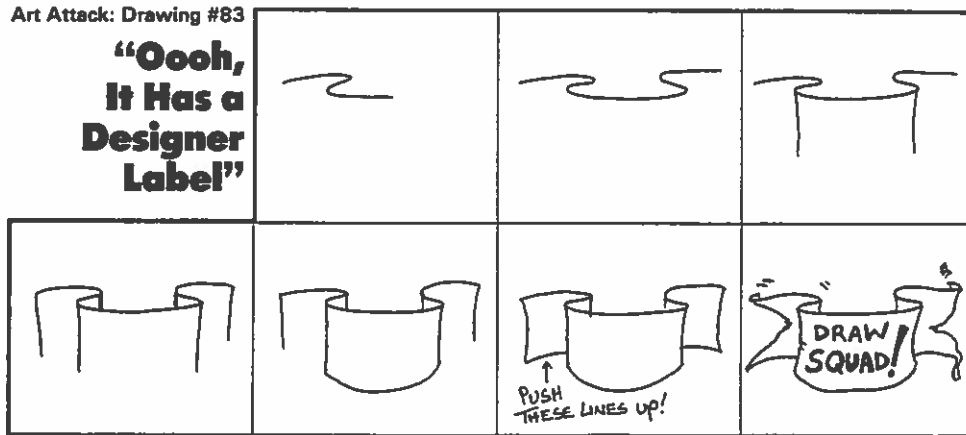

Art Attack: Drawing #84

Furblina's Checkbook

