

# LESSON 13

## Warm-up

Shake out your hands!

Get your fingers loose with 42 3 seconds of drawerize. Stand up, flap your arms and sing in a jolly voice: "Oh, I'm a Draw Squad Maniac. Oh, I love to draw!" Feel better? Great! Here we go with Lesson 13. Only 17 more to go! Is your pencil sharp? Did you think positively today? Great! Draw 17 foreshortened circles!

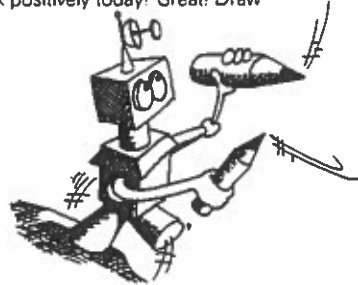
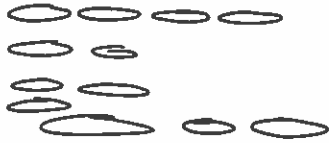

## Key Drawing Word: Intermediate Shading

**SHADE, SHADOW & SHADING:** Have you ever sat under a tree on a hot, bright, sunny day? Why did you sit there? More than likely you sat there to be in the **shade**—to get out of the sun—to be in the **shadow** of the tree! Was it darker or lighter in the **shadow** under the tree? Yes! It was darker! Why was it darker? Because the sunlight was partially blocked by the shape of the tree. If you were drawing the grass under the tree you would have to draw the **shadow** darker than the grass which is not in the shade. That is what you do when you **shade**. **Shading** is very important to drawing. **Shading** makes shapes and objects you draw look three-dimensional, to have form or volume, and to look more realistic. **Shading** makes what you are drawing look as if you could walk around it, sit under it or climb it. **Shading** is drawing from dark to light or from light to dark to make things look more interesting—to show how the light from the sun, a ceiling light, candlelight or some other light source hits a shape or object.

James M. Clarke, Board of Directors, National Art Education Association/Texas



The key word symbol for shading is:

### Art Attack: Drawing #73

## The Draw Squad Super Jet

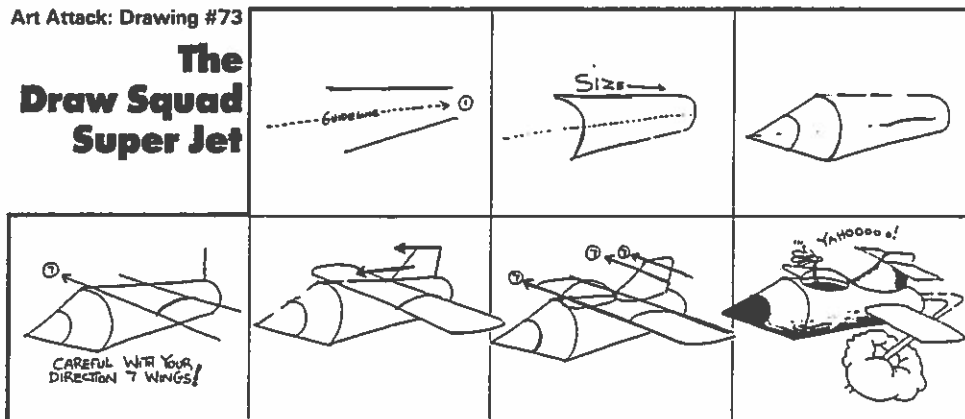

### Art Attack: Drawing #74

## A Doughnut For Your Drawing Diet

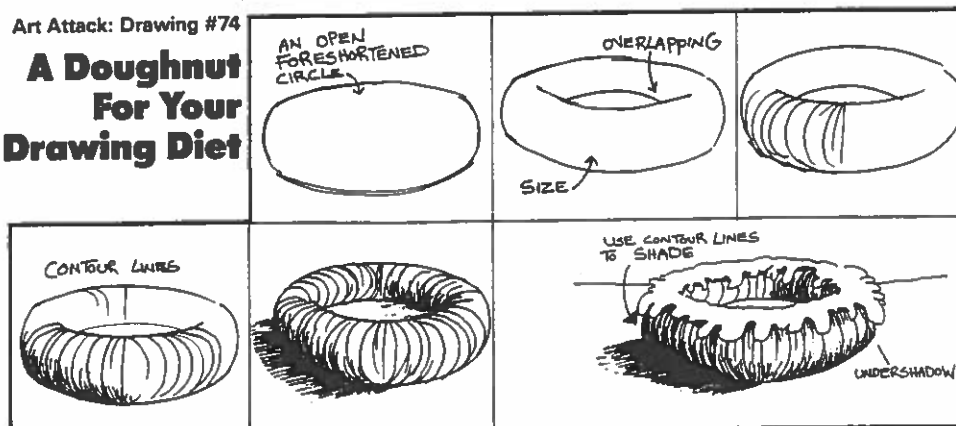

Art Attack: Drawing #75

### Three Steps to Success

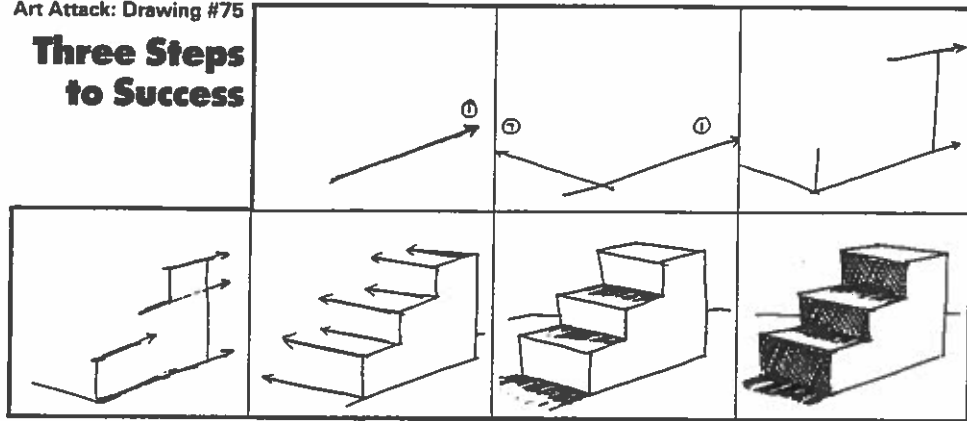

Art Attack: Drawing #76

### A Flower For Mom

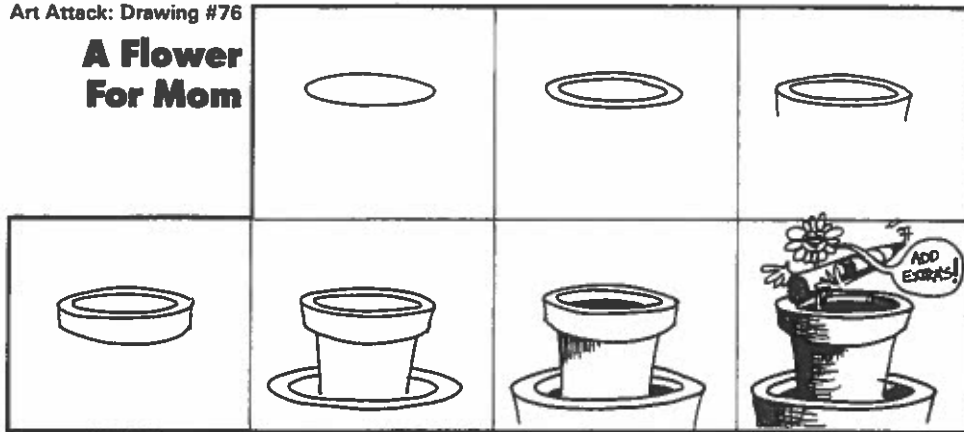

Art Attack: Drawing #77

### Time For Lunch

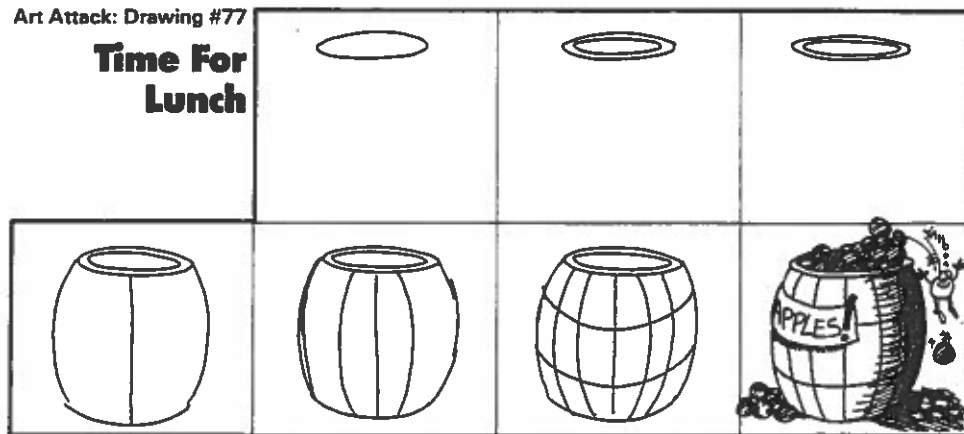

Art Attack: Drawing #78

### The Draw Squad Luxury Yacht

