

LESSON 12

Warm-up

Let's loosen up and get ready to launch into the world of drawing. Shake out your hands, roll your pencil between your fingers, and pull up your chair. Open your sketchbook to your last drawings. Spend a few minutes darkening edges and shadows. This will get your hand rolling and help you recall the important points of the last lesson. Now, vigorously draw a row of dashes.



Key Drawing Word: Intermediate Surface

SURFACE: In Dutch this is called "dychtby un verweg" which translates as "near and far." Place some objects on a table such as a teapot, some fruit and a few eggs. Now stand back and look at the objects. Notice how the nearer items appear lower in your view. This is what "dychtby un verweg" means.

Hans van der Veen. Art Educator/Groningen, Netherlands

The key word symbol for surface is:

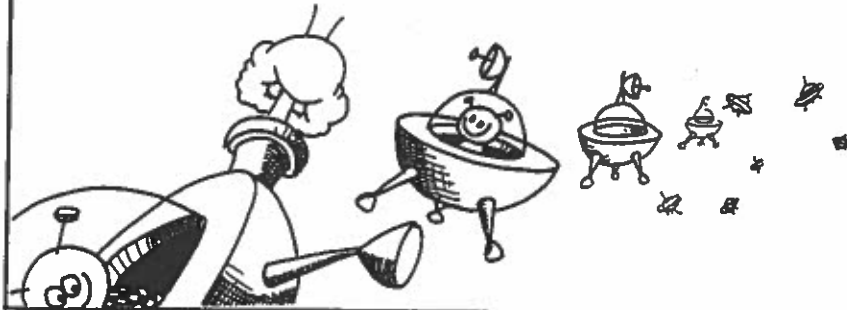

Art Attack: Drawing #67

Gingerbread Man Having a Bad Day

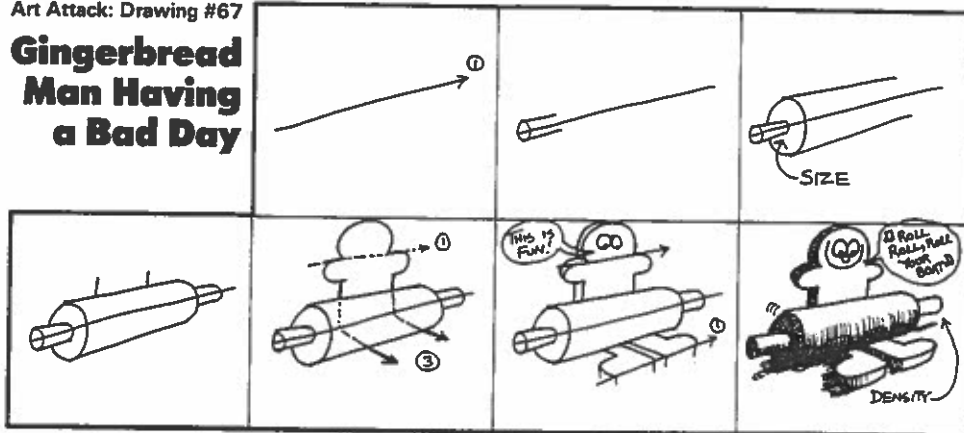

Art Attack: Drawing #68

Gingerbread Man's Doorstep

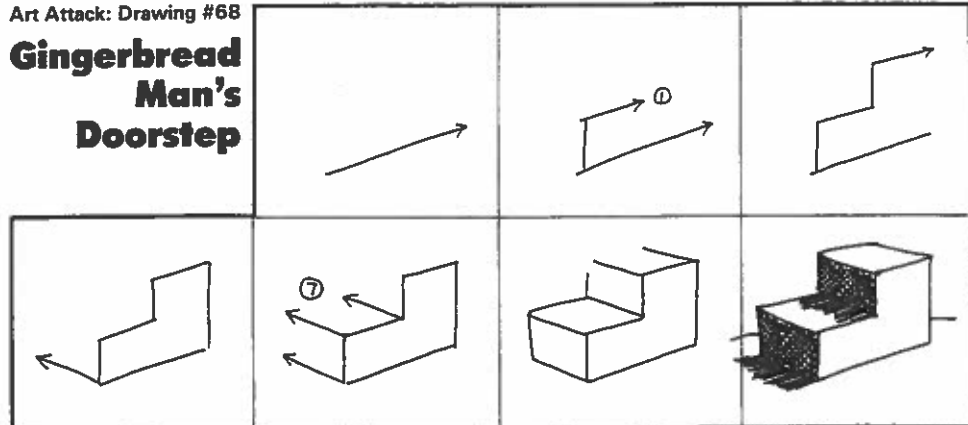

Art Attack: Drawing #69

Gingerbread Man's Thirst Quencher

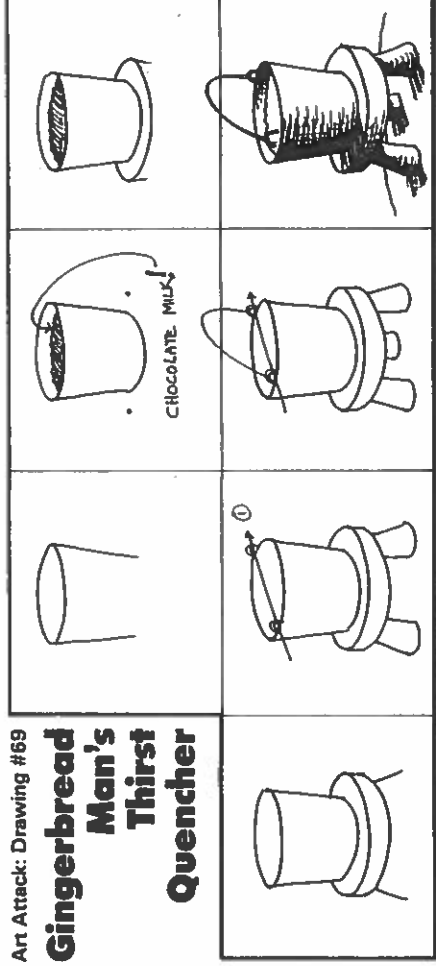

Art Attack: Drawing #70

Gingerdog's Dinner

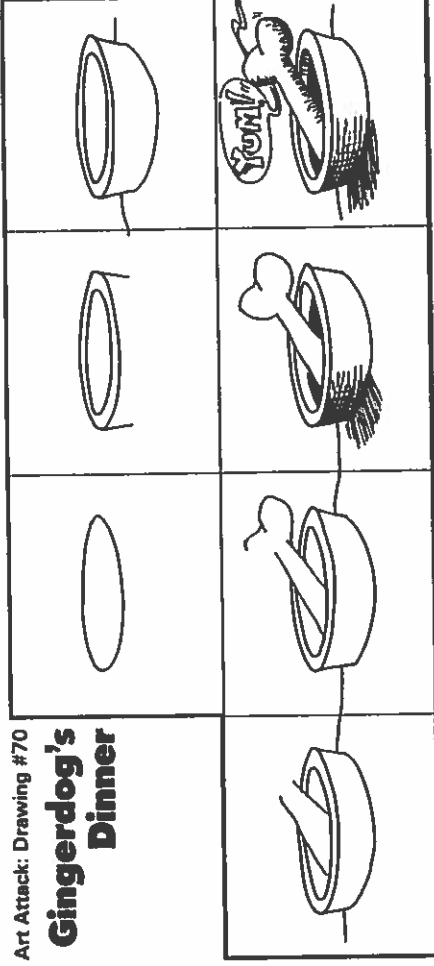

Art Attack: Drawing #71

Gingerbread Man's Birthplace

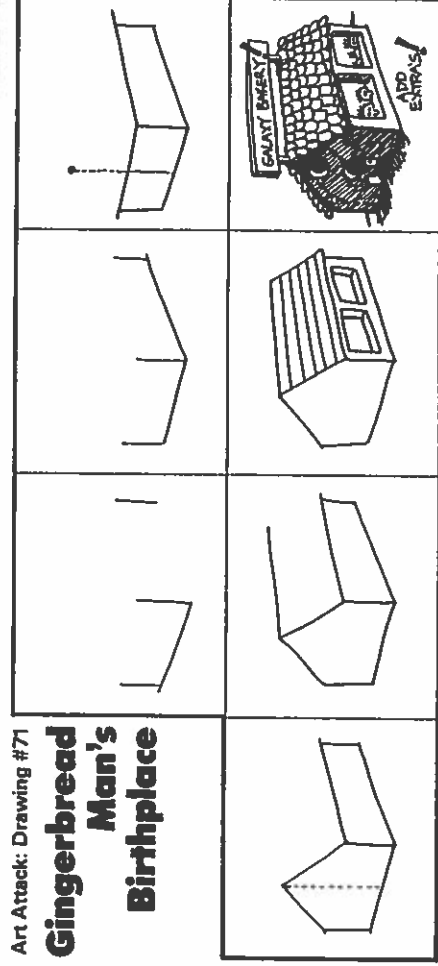

Art Attack: Drawing #72

Gingerbread Man's New Porsche

